

Z961/...

Mat.: 3.2315

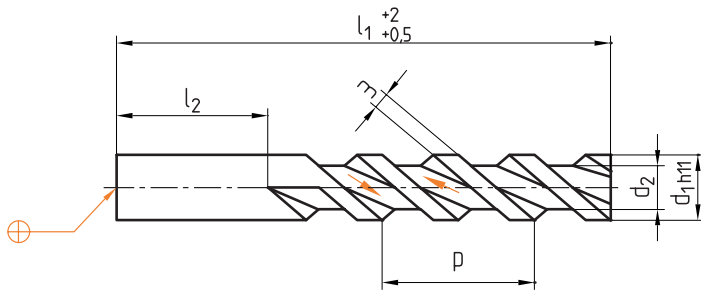

► Info

p	l ₂	d ₂	d ₁	l ₁	Nr./No.
28	35	8	12	125	Z961/12x125
				200	12x200
		11	16	125	16x125
				200	16x200
		13	20	125	20x125
				200	20x200
15	25	125	25x125		
		200	25x200		

p	l ₂	d ₂	d ₁	l ₁	Nr./No.
36	35	22	32	125	Z961/32x125
				200	32x200
		26	40	125	40x125
				200	40x200
		32	50	125	50x125
				200	50x200

Z962/...

Mat.: 2.0401

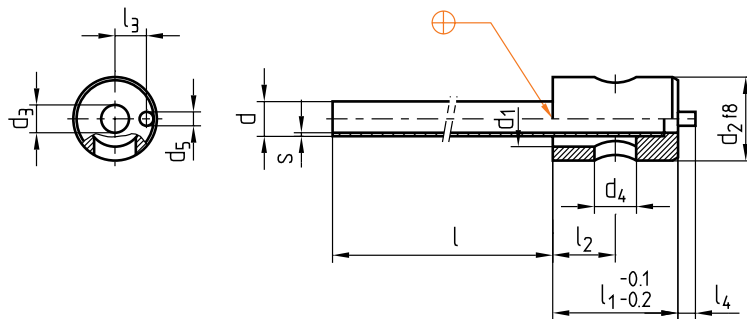

► Info

l ₄	l ₃	l ₂	l ₁	d ₅	d ₄	d ₃	d ₁	d ₂	d	s	l	Nr./No.	
2,5	3,5	9	16	2	4	2	4	10	2,6	0,3	100	Z962/10/ 2,6x0,3x100	
											200	10/ 2,6x0,3x200	
						2,4	5	3	100	10/ 3 x0,3x100			
					3	6	4	0,5	100	10/ 3 x0,3x200			
								200	10/ 4 x0,5x100				
					4,5	18	6	8	12	5	4	8	12
	200	10/ 4 x0,5x200											
	315	12/ 5 x0,5x160											
	160	12/ 5 x0,5x315											
	160	16/ 6 x0,5x160											
	315	16/ 6 x0,5x315											
	6	12	5	12	16	6	5	12	16	6	1	160	16/ 6 x0,5x160
315												16/ 6 x0,5x315	
160												18/ 8 x1 x160	
315												18/ 8 x1 x315	
160												20/10 x1 x160	
315												20/10 x1 x315	
7	14	6	14	18	8	5	14	18	8	1	160	18/ 8 x1 x160	
											315	18/ 8 x1 x315	
											160	20/10 x1 x160	
											315	20/10 x1 x315	
											160	20/10 x1 x160	
											315	20/10 x1 x315	
8	20	8	8	16	10	5	16	20	10	1	160	20/10 x1 x160	
											315	20/10 x1 x315	
											160	25/12 x1 x160	
											315	25/12 x1 x315	
											160	25/12 x1 x160	
											315	25/12 x1 x315	
3	9,5	13	25	3	10	10	20	25	12	1	160	25/12 x1 x160	
											315	25/12 x1 x315	

This is trial version
www.adultpdf.com